

S5310

07-14 TOYOTA FJ CRUISER 4.0L, CAT BACK,
2.5" SINGLE SIDE, OFFROAD TAIL

MBRP

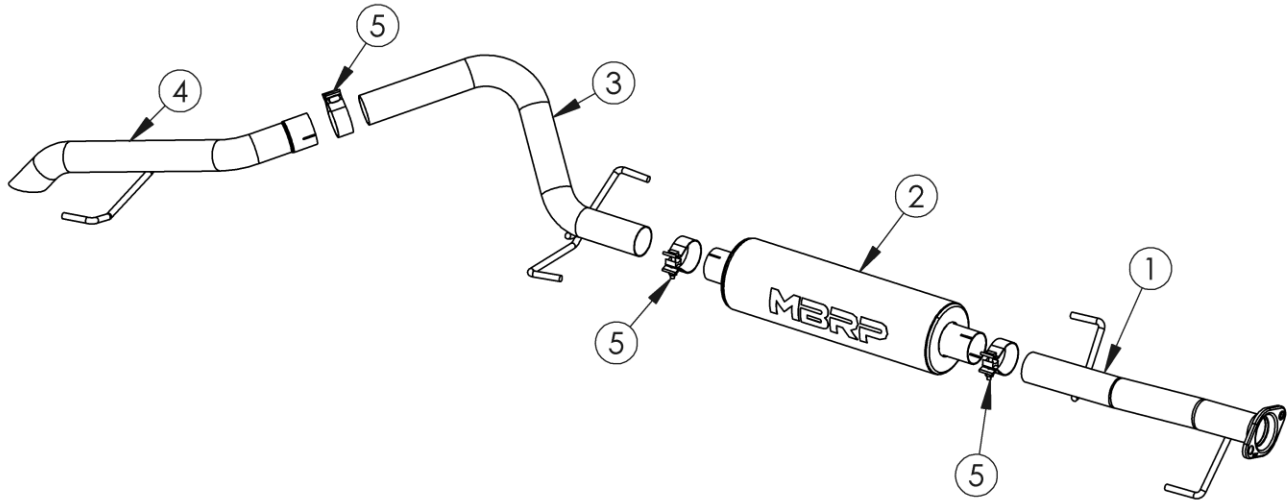

1. EXTENSION PIPE
2. MUFFLER
3. OVER-AXLE PIPE
4. TAIL PIPE
5. 2 1/2" CLAMP (3 PCS)

PLEASE READ BEFORE STARTING INSTALLATION

While MBRP has made every effort to ensure that all components of this system are of superior quality and properly packaged, it is the installer's responsibility to ensure the following before removal of the factory exhaust:

- that ALL components shown above are present.
- that ALL mating components fit together.
- that there are no damaged components.
- that the system you have purchased is appropriate for your vehicle year, model and configuration.
- that the system will not interfere with any modifications previously installed or planned.
- that you have read and understand these instructions.

If you have any questions or are uncertain about any aspect of the installation of this system to your vehicle please contact your dealer before commencing installation.

MBRP

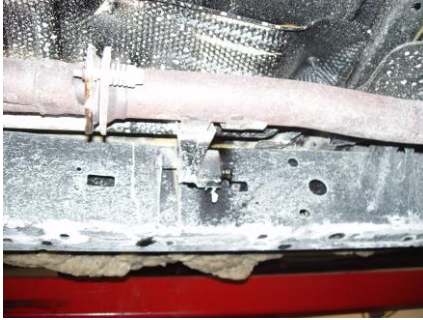

Figure 1



Figure 2



Figure 3

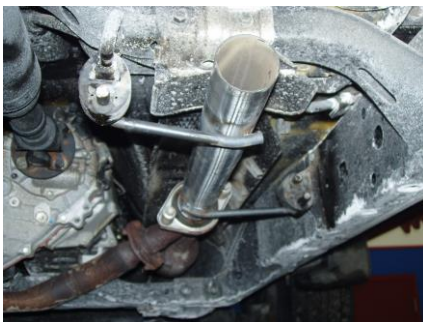

Figure 4

Removal of stock system:

1. Apply a penetrating lubricant liberally to all exhaust fasteners, hangers and rubber insulators.
2. Remove the bolts and springs holding the front flange together and disconnect exhaust system. Do not discard this hardware it will be reused during the installation **Refer to Figure 1.**
3. Remove hardware from Flange behind muffler. Remove the hangers from the rubber insulators. Remove the exhaust from the vehicle. **Refer to Figures 2 & 3.**

Installation of **MBRP** Performance Exhaust:

1. Using the bolts previously removed from the flange slide the springs over the bolts and loosely attach the **Extension Pipe** to the flange using the fasteners. **Refer to Figure 4.**

MBRP



Figure 5

2. Slide a **2 ½” Clamp** over the **Extension Pipe** and install muffler onto the Extension Pipe. **Refer to Figure 5.**

3. Slide a **2 ½” Clamp** over the outlet side of the Muffler. Position the **Over Axle Pipe** over the axle and loosely attach it to the muffler. Install the **Over Axle Pipe** hangers into the factory rubber insulator. **Refer to Figure 6.**



Figure 6

4. Slide a **2 ½” Clamp** over the **Tail Pipe** and install it to the **Over Axle Pipe**. **Refer to Figure 7.**

5. Slide **Tail Pipe** hanger into rearmost rubber insulator and reattach the frame. **Refer to Figure 7.**

6. Align the exhaust as required. Starting at the front of the exhaust, tighten all clamps and connections.



Figure 7

7. Tighten all hardware and clamps, starting at the front and working rearward to secure the system. Check along the full length of the exhaust system to ensure there is adequate clearance for fuel lines, vent lines, brake lines, frame, bodywork, suspension and any wiring, etc. If there is any interference detected, relocate or adjust to provide adequate clearance. Ensure all clamp connections are secure and components are unable to rotate or slide. Band clamps require approximately 45 lb-ft (60 N-m) of torque. Verify clearances, system security and band clamp torque after 30-60 miles (50-100 km) of driving.

Congratulations! You are ready to begin experiencing the improved power, sound and driving excitement of your **MBRP** performance exhaust system. We know you will enjoy your purchase.