

S5253

2015-UP F150 2.7/3.5L ECOBOOST 3"
SINGLE SIDE - ALL WHEELBASES, EXCLUDING
2019 FORD F150 LIMITED 3.5L HIGH OUTPUT

MBRP

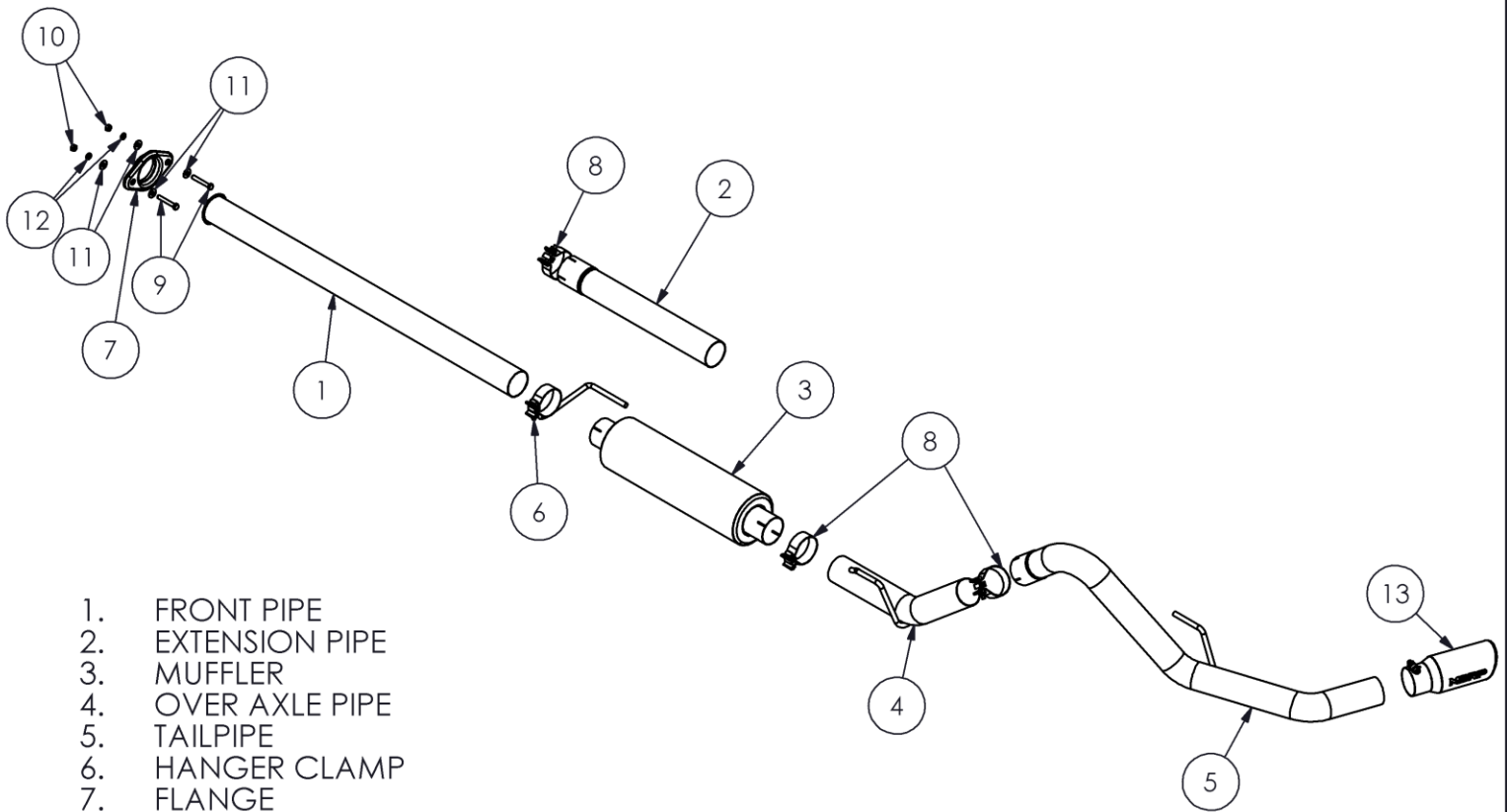

1. FRONT PIPE
2. EXTENSION PIPE
3. MUFFLER
4. OVER AXLE PIPE
5. TAILPIPE
6. HANGER CLAMP
7. FLANGE
8. 3" CLAMP [3 PCS]
9. HEX BOLT 3/8" [2 PCS]
10. HEX NUT 3/8" [2 PCS]
11. FLAT WASHER 3/8" [4 PCS]
12. LOCK WASHER 3/8" [2 PCS]
13. TIP

NOTE: ALUMINIZED SYSTEMS USE SADDLE CLAMPS

PLEASE READ BEFORE STARTING INSTALLATION

While MBRP Inc. has made every effort to ensure that all components of this system are of superior quality and properly packaged, it is the installer's responsibility to ensure the following before removal of the factory exhaust:

- that ALL components shown above are present.
- that ALL mating components fit together.
- that there are no damaged components.
- that the system you have purchased is appropriate for your vehicle year, model and configuration.
- that the system will not interfere with any modifications previously installed or planned.
- that you have read and understand these instructions.

If you have any questions or are uncertain about any aspect of the installation of this system to your vehicle please contact your dealer before commencing installation.

MBRP

Removal of Stock System:



Figure 1

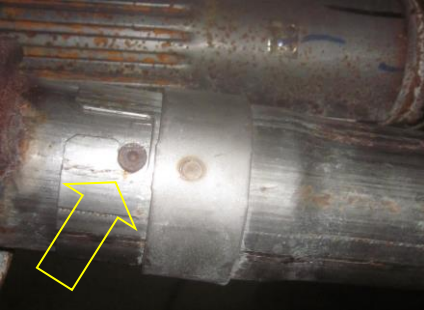

Figure 2



Figure 4



Figure 5



Figure 6

1. Apply a penetrating lubricant liberally to all hangers and rubber insulators.
2. Loosen the factory clamp in front of the muffler.
3. Loosen the factory extension pipe flange bolts.
Refer to Figure 1.

4. Rotate the factory extension pipe to release the factory muffler inlet locking boss.
Refer to Figure 2.

5. Remove the factory muffler assembly from the hangers and remove from the vehicle.

6. Remove the factory extension pipe bolts and remove the factory extension pipe from the vehicle.

Installation of MBRP Performance Exhaust:

1. Determine the overall length of the **Front Pipe** and **Extension Pipe** (if required).
Refer to figure 3.

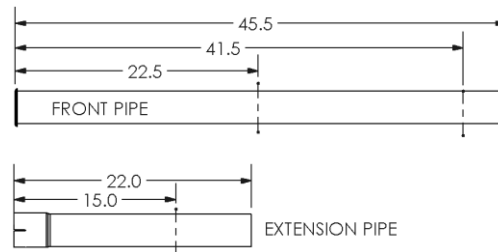

WHEELBASE	FRONT PIPE LENGTH	EXTENSION PIPE LENGTH
122" RC 6.5' BOX	22.5	NONE
141" RC 8' BOX	41.5	NONE
145" EC 6.5' BOX/ SC 5.5' BOX	45.5 (NO CUT)	NONE
157" SC 6.5' BOX	45.5 (NO CUT)	15"
164" EC 8' BOX	45.5 (NO CUT)	22" (NO CUT)

Figure 3

2. Slide the **Flange** onto the **Front Pipe** and loosely install the **Front Pipe** using the supplied **Hardware**.
Refer to Figure 4.

3. Install the **Hanger Clamp** into the second factory isolator.
Refer to Figure 5.

MBRP



Figure 7

4. Place the **Front Pipe** or **Extension Pipe** (if required) into the **Hanger Clamp**.

Refer to Figure 6.

5. Install the **Muffler** onto **Extension Pipe** and lightly secure with the **Hanger Clamp**. Do not completely tighten at this time.

Refer to Figure 7.

6. Place a **3" Clamp** over the **Muffler** outlet and insert the **Over Axle Pipe** into the **Muffler** and factory isolator.

Refer to Figure 8.



Figure 8

7. Install a **3" Clamp** and the **Tail Pipe** onto the **Over Axle Pipe** and into the factory isolator. Snug, but do not completely tighten the **3" Clamp**.

Refer to Figure 9.

8. Install the **Exhaust Tip** and adjust to your liking.

Refer to Figure 10.

9. Once everything is aligned, completely tighten all **Clamps** and **Hardware**.

10. Check along the whole length of the exhaust system to ensure that there is adequate clearance around the spare tire, fuel and brake lines or any wiring. If any interference is detected relocate or adjust.



Figure 9



Figure 10



Congratulations! You are ready to begin experiencing the improved power, sound and driving experience of your **MBRP** performance exhaust system. We know you will enjoy your purchase.