

# S5142

2009-2018 RAM 1500,  
2019 RAM 1500 CLASSIC, 5.7L HEMI,  
3" CAT BACK, SINGLE SIDE

# MBRP®

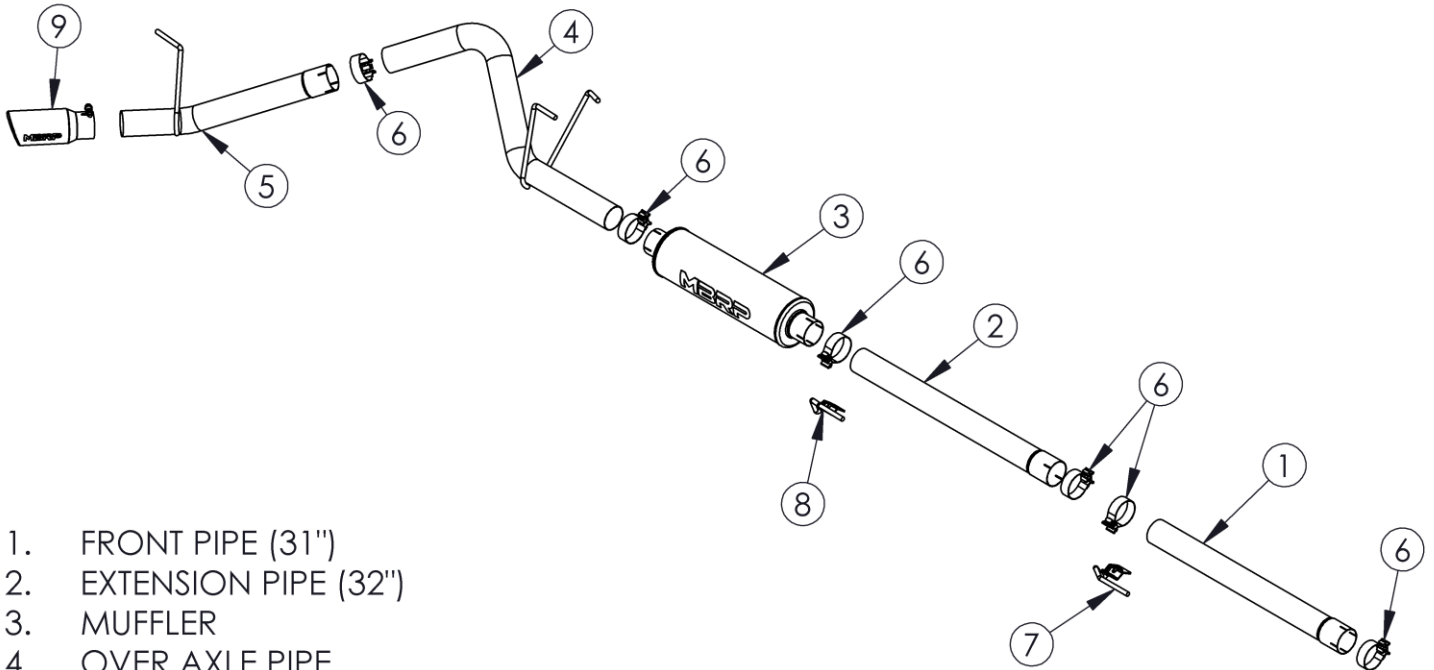

1. FRONT PIPE (31")
2. EXTENSION PIPE (32")
3. MUFFLER
4. OVER AXLE PIPE
5. TAIL PIPE
6. 3" CLAMP (4PCS)
7. HANG TIGHT™ HANGER
8. HANG TIGHT™ HANGER
9. EXHAUST TIP

## PLEASE READ BEFORE STARTING INSTALLATION

**While MBRP has made every effort to ensure that all components of this system are of superior quality and properly packaged, it is the installer's responsibility to ensure the following before removal of the factory exhaust:**

- that ALL components shown above are present.
- that ALL mating components fit together.
- that there are no damaged components.
- that the system you have purchased is appropriate for your vehicle year, model and configuration.
- that the system will not interfere with any modifications previously installed or planned.
- that you have read and understand these instructions.

If you have any questions or are uncertain about any aspect of the installation of this system to your vehicle please contact your dealer before commencing installation.

# MBRP

## 2009-18 Dodge Ram 1500 5.7L HEMI 2019 Dodge Ram 1500 Classic 5.7L HEMI

### Removal of stock system:

1. Apply a penetrating lubricant liberally to all exhaust fasteners, hangers and rubber insulators.
2. Remove the clamp just after the Y pipe. Refer to Figure 1.
3. Remove the clamp from the rear of the muffler. Refer to Figure 2.
4. Remove the stock exhaust from the existing rubber isolators and remove the system from the vehicle.

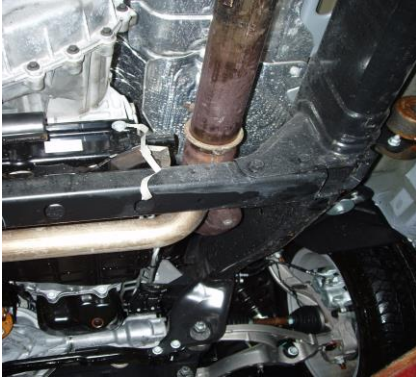

Figure 1



Figure 2

### Installation of MBRP Performance Exhaust:

1. Install **Front Pipe** over the existing Y using a **3" Clamp**. The **Front Pipe** will need to be cut depending on Cab Type. Refer to **Chart 1**. Leave the **3" Clamp** loose enough for adjustment. Refer to **Figure 4**. Note the front pipe will not be required on a regular cab short box.



Figure 3

Cab Type	Box Length	Wheel Base	Front Pipe Required	Cut Required = New Length
Regular	6'4"	120.5	No	N/A
Regular	8'	140.5	Yes	Yes = 23"
Quad Cab	6'4"	140.5	Yes	Yes = 23"
Crew Cab	5'7"	140.5	Yes	Yes = 23"
Crew Cab	6'4"	149.5	Yes	No = 31"

Chart 1



Figure 4

2. Install the **Hang Tight™ Hangers** onto **3.0" Band Clamps** using the procedure shown below. (Hang Tight™ Hanger not exactly as shown)

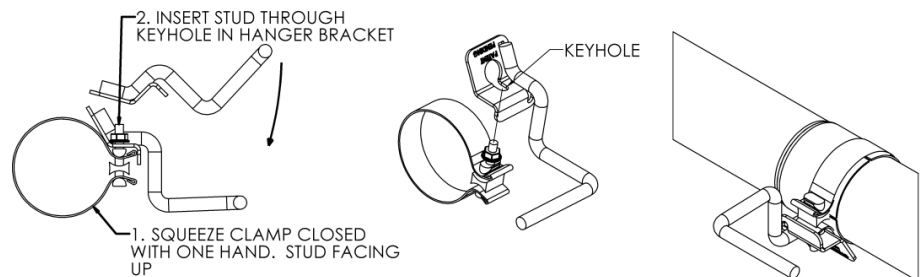

3. ROTATE HANGER BRACKET TO SEAT THREADED STUD IN SLOT. BE SURE THE NUT IS ABOVE THE BRACKET

AS INSTALLED ON VEHICLE

# MBRP



Figure 5



Figure 6



Figure 7



Figure 8

3. Slide the front **Hang Tight™ Hanger Clamp Assembly** over the **Front Pipe**. Slide the hanger into the existing rubber insulator. Install the **Extension Pipe** to the **Front pipe** using a **3" Clamp**. Refer to **Figure 4**.

4. Install the second **Hang Tight™ Hanger Clamp Assembly** over the **Extension Pipe** and into the existing rubber isolator. Refer to **Figure 5**.

5. Slide the **Muffler** onto the **Extension Pipe** and attach it using the **Hang Tight™ Hanger Clamp Assembly**. Refer to **Figure 6**.

6. Install the **Over Axle Pipe** hangers into the existing rubber insulators and on to the outlet of the **Muffler**. Refer to **Figure 7**.

7. Install **Tail Pipe** to the **Over Axle Pipe** using a **3" Clamp**. Install and adjust the **Exhaust Tip** to suit. Using a 17mm wrench tighten the lock bolt located on the **Exhaust Tip**. Refer to **Figure 8**.

8. Tighten all hardware and clamps, starting at the front and working rearward to secure the system. Check along the full length of the exhaust system to ensure there is adequate clearance for fuel lines, vent lines, brake lines, frame, bodywork, suspension, and any wiring, etc. If there is any interference detected, relocate, or adjust to provide adequate clearance. Ensure all clamp connections are secure and components are unable to rotate or slide. Band clamps require approximately 45 lb-ft (60 N-m) of torque. Verify clearances, system security and band clamp torque after 30-60 miles (50-100 km) of driving.



**Congratulations!** You are ready to begin experiencing the improved power, sound and driving experience of your **MBRP** performance exhaust system. We know you will enjoy your purchase.